

Versa64Cart

Project Documentation

BWACK's Versa64Cart

Project number: 121

Revision: 1.5

Date: 07.05.2020

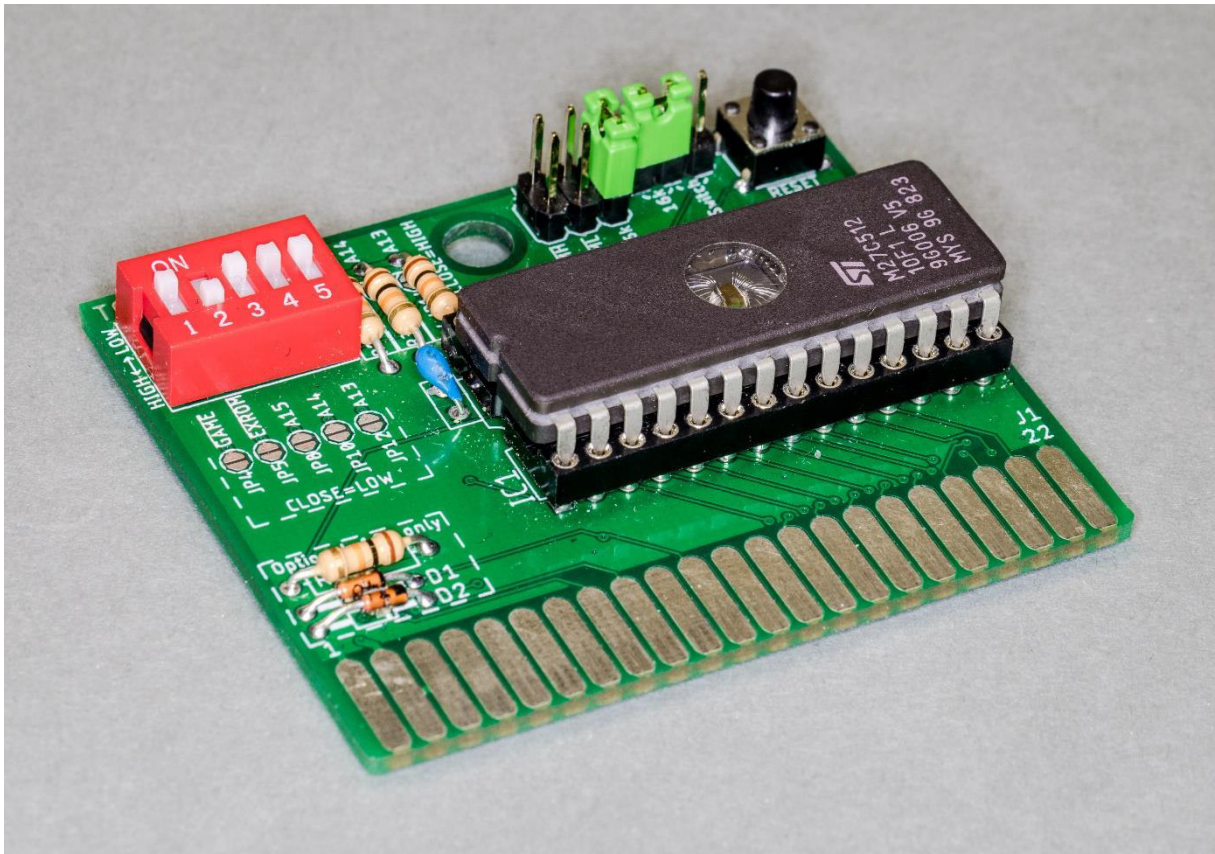

Versa64Cart v1.5

Module Description

Content

1. Introduction	2
2. Configuration	2
2.1. Explanation.....	2
2.2. Jumper & DIP-Switch Settings	3
2.3. Bank Switching	3
2.4. Solder Bridges.....	4
3. Assembly of the Versa64Cart	4
4. Retrieving the binary and the settings from a CRT file	5
4.1. VICE cartconv	5
4.2. Example I	5
4.3. Example II.....	6
4.4. Example III.....	7
4.5. Example IV	7
5. EPROMs.....	8
6. Startup and Trouble shooting.....	8
7. Revision History.....	9
7.1. Rev. 1.1 ⇒ Rev. 1.2	9
7.2. Rev. 1.2 ⇒ Rev. 1.3	9
7.3. Rev. 1.3 ⇒ Rev. 1.4	9
7.4. Rev. 1.4 ⇒ Rev. 1.5	9

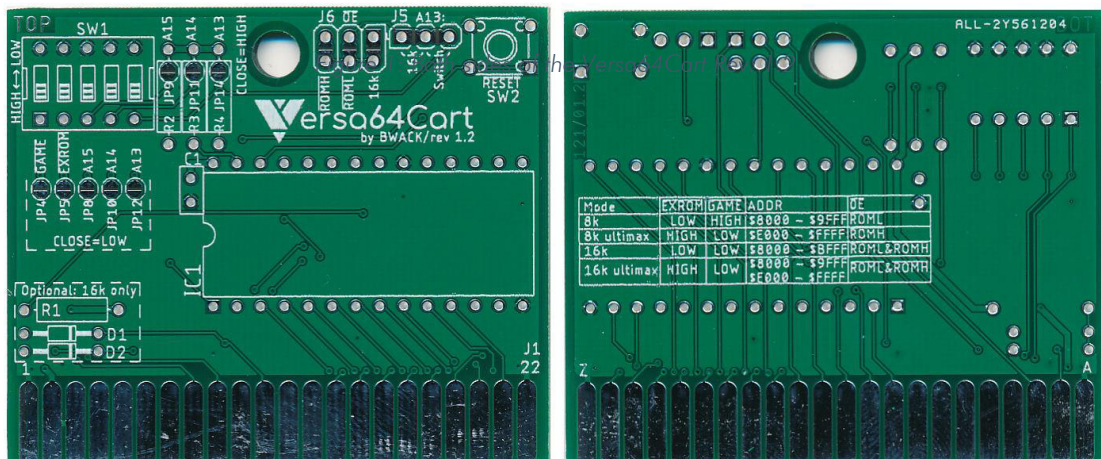

1. Introduction

The Versa64Cart is a generic EPROM cartridge for the Commodore C64 and C128. It can be configured as 8k, 16k, 8k ultimax or 16k ultimax cartridge. Further on, the most sufficient address bits of the EPROM can be set by a DIP-switch which offers a manual bank switching for multi game/multi ROM cart option.

The Versa64Cart is not suitable to run a Kernal or software, which require bank switching by that software (e.g. games > 16k).

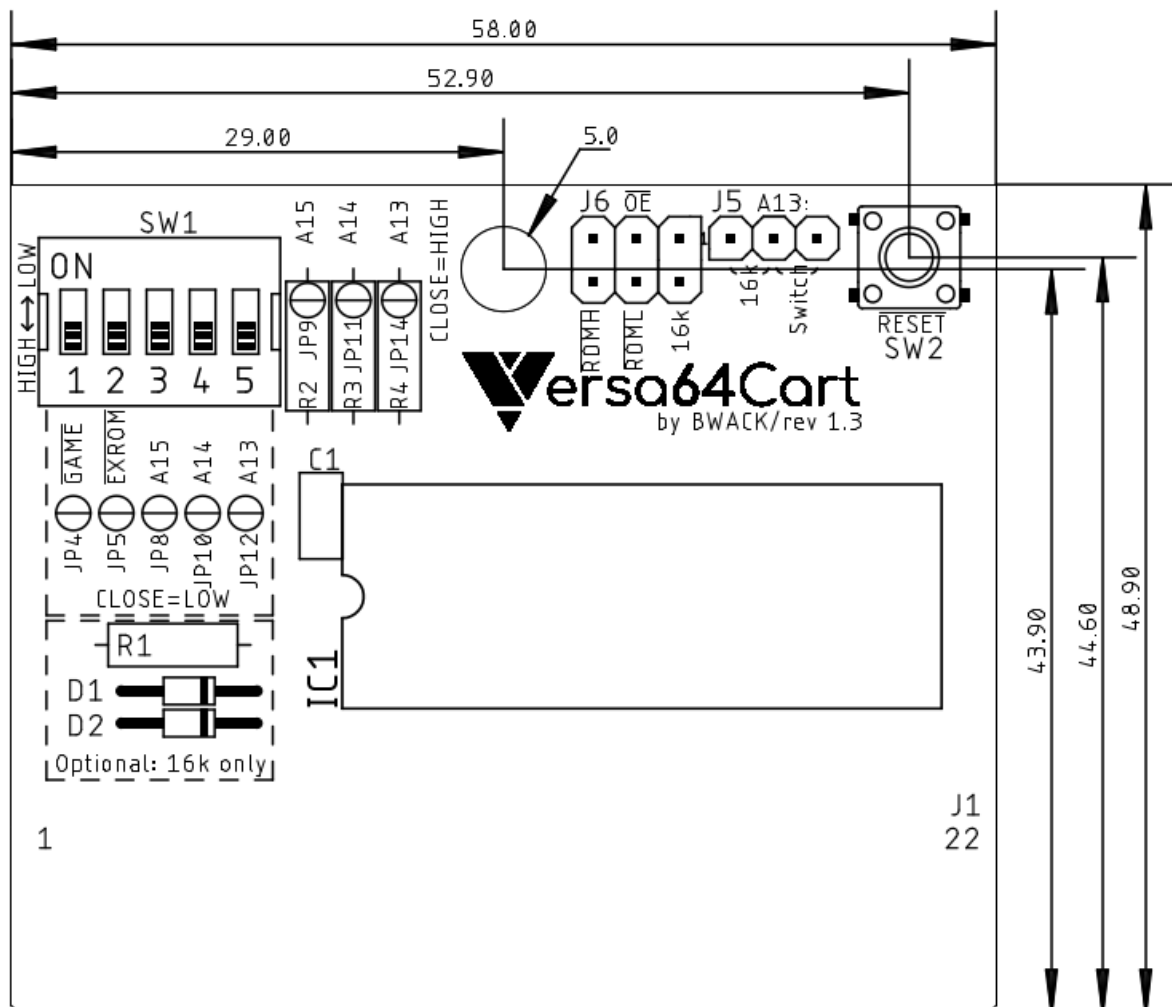

Figure 2: Versa64Cart - placement and dimensions

2. Configuration

2.1. Explanation

The extension cartridges signalize their configuration with two flags. Those are $\overline{\text{GAME}}$ and $\overline{\text{EXROM}}$. For addressing the EPROM, the C64 offers two chip-select signals for an 8kB address space, which are $\overline{\text{ROML}}$ and $\overline{\text{ROMH}}$. The chip-select signals are required to locate the EPROM

content within the address space of the C64. It is possible to use either $\overline{\text{ROML}}$, $\overline{\text{ROMH}}$ or combining both to get a 16kB address space in total.

Mode	$\overline{\text{EXROM}}$	$\overline{\text{GAME}}$	$\overline{\text{OE}}$	Address space
8k	LOW	HIGH	$\overline{\text{ROML}}$	0x8000 – 0x9FFF
8k ultimax	HIGH	LOW	$\overline{\text{ROMH}}$	0xE000 – 0xFFFF
16k	LOW	LOW	$\overline{\text{ROML}}$ & $\overline{\text{ROMH}}$ = "16k"	0x8000 – 0xBFFF
16k ultimax	HIGH	LOW	$\overline{\text{ROML}}$ & $\overline{\text{ROMH}}$ = "16k"	0x8000 – 0x9FFF + 0xE000 – 0xFFFF

Table 1: Cartridge configuration

In the "ultimax" modes, the Kernal ROM (0xE000 – 0xFFFF) is replaced by the content of the EPROM of the Versa64Cart. The Reset vector is located at 0xFFFC and 0xFFFD. This is a guidepost for the microprocessor, which shows where to start the execution after the processor was powered up (or received a RESET pulse). This way, the software in the EPROM will completely take control.

In EXROM mode, the C64 Kernal (the one on the mainboard) will check the memory locations 0x8004-0x8008 for the "cartridge signature" CBM80 (PETSCII 0xC3, 0xC2, 0xCD, 0x38, 0x30). If this sequence is found, the execution will follow the cartridge cold start vector located at the first two memory addresses of the EPROM (0x8000 and 0x8001 in the C64's address space).

2.2. Jumper & DIP-Switch Settings

The DIP-Switch SW1 configures the cartridge mode and the three most sufficient address bit of the EPROM (the "bank switching"). Annotation: ON position connects the signal to ground (=LOW).

The jumper J6 ($\overline{\text{OE}}$) sets the chip select signal for the EPROM. It can be $\overline{\text{ROML}}$, $\overline{\text{ROMH}}$ or "16k"(this is a diode logic AND of $\overline{\text{ROML}}$ and $\overline{\text{ROMH}}$).

The jumper J5 (A13) can be set to "Switch" or "16k". "Switch" means, that A13 is set by the DIP-Switch, "16k" means, that A13 is controlled by the $\overline{\text{ROML}}$ signal.

A 16k cartridge requires both jumpers (J5 and J6) set to "16k".

For the required settings refer to Table 1.

2.3. Bank Switching

The EPROM offers more memory (27C512 = 64kB), than it is required for a generic 8k or 16k cartridge. On account of this an EPROM can keep the content of several cartridges. The DIP-Switch SW1 (3, 4, 5 = A15, A14 and A13) selects, which of these cartridges is selected. In 16k mode, the setting of A13 is ignored.

The DIP-Switch can be replaced with a jumper.

DIP-Switch			Address Bits			EPROM Address (Offset)
3	4	5	A15	A14	A13	
ON	ON	ON	L	L	L	0x0000 – 0x1FFF
ON	ON	OFF	L	L	H	0x2000 – 0x3FFF
ON	OFF	ON	L	H	L	0x4000 – 0x5FFF
ON	OFF	OFF	L	H	H	0x6000 – 0x7FFF
OFF	ON	ON	H	L	L	0x8000 – 0x9FFF
OFF	ON	OFF	H	L	H	0xA000 – 0xBFFF
OFF	OFF	ON	H	H	L	0xC000 – 0xDFFF
OFF	OFF	OFF	H	H	H	0xE000 – 0xFFFF

Table 2: 8k cartridges memory banks

DIP-Switch			Address Bits			EPROM Address (Offset)
3	4	5	A15	A14	A13	
ON	ON	X	L	L	X	0x0000 – 0x3FFF
ON	OFF	X	L	H	X	0x4000 – 0x7FFF
OFF	ON	X	H	L	X	0x8000 – 0xBFFF
OFF	OFF	X	H	H	X	0xC000 – 0xFFFF

Table 3: 16k cartridges memory banks

The C64 address must not be confused with the EPROM Address offset.

2.4. Solder Bridges

Instead of setting jumpers and the DIP-Switch, solder bridges can be utilized to configure the Versa64Cart. This is an option, in case the configuration of the Versa64Cart is not prone to be changed. Solder bridges are used to “hard wire” the configuration.

Signal	HIGH	LOW
$\overline{\text{GAME}}$	JP4 = open	JP4 = closed
$\overline{\text{EXROM}}$	JP5 = open	JP5 = closed
A15	JP8 = open, (JP9 = closed)	JP8 = closed, (JP9 = open)
A14	JP10 = open, (JP11 = closed)	JP10 = closed, (JP11 = open)
A13	JP12 = open, (JP14 = closed)	JP12 = closed, (JP14 = open)

Table 4: Configuration with solder bridges

The jumpers in () are only required, in case the pull-up resistors R2, R3 and R4 are not populated. **Never (!!!!) close both jumpers of one address signal. It cannot be LOW and HIGH at the same time, this will produce a SHORT CIRCUIT!!!!**

The footprints of the jumpers J5 and J6 are designed to be solder bridged, when not populated.

3. Assembly of the Versa64Cart

The Versa64Cart can work with a minimum of components when being configured with solder bridges. Just the EPROM and a 100nF capacitor is required.

- The reset switch is nice to have, but it is just an option.
- The DIP-switch can be replaced by configuring the solder bridges JP4, 5, 8, 10 and 12.

- The pull-up resistors (R2-4) can be omitted and JP9, 11, 14 can be utilized to set a HIGH level on A15 ... A13 (**BE CAREFUL, see warning above!**). **If you are not sure, keep the pull up resistors.**
- J5 and J6 can be hard wired with solder bridges.
- R1, D1 and D2 are only required in 16k modes.
- The EPROM can be soldered, a socket is not necessary

Soldering the EPROM can be required if a shallow cartridge case is used. A socket might add too much height. In this case, it is advised to test the EPROM with a Versa64Cart with a socket before.

4. Retrieving the binary and the settings from a CRT file

4.1. VICE cartconv

The CRT file format is created to emulate cartridges with VICE or devices like the Ultimate II+ etc. It should not be programmed into an EPROM; this will not work.

Instead, the binary has to be retrieved from the CRT file. The binary is a file that can be used for programming EPROMs. Also, it is possible to find out the required settings for GAME and EXROM .

The utility that is used here is CARTCONV, which is a command line tool that comes with VICE (C64 emulator). For the examples, CARTCONV and the cartridge files are copied to the same directory. To start, enter *cmd* into the search box on the task bar of Windows 10.

First the CRT information is required. Enter the following command

```
cartconv -f mycartridge.crt
```

mycartridge.crt stands for the crt file, that you want to convert.

The second step is to generate a *.bin file from the *.crt. The *.bin file can be used to program EPROMs.

```
cartconv -i mycartridge.crt -o mycartridge.bin
```

4.2. Example I

```
C:\cartconv>cartconv -f deadtest.CRT
CRT Version: 1.0
Name: C64DEADTESTREV718220
Hardware ID: 0 (Generic Cartridge)
Mode: exrom: 1 game: 0 (ultimax)

offset  sig  type  bank  start  size  chunklen
$000040 CHIP ROM   #000  $e000 $2000 $2010

total banks: 1 size: $002000
```

The important information is colored **red** in the above example.

First of all, **it has to be a generic cartridge** (Hardware ID 0). Many (game or special) cartridges have additional hardware build it, that is required for proper operation. That might be one of manifold automatic bank switching circuits, a freezer circuit like in the Final Cartridge etc.

Next, $\overline{\text{EXROM}}$ has to be 1 (HIGH) and $\overline{\text{GAME}}$ has to be 0 (LOW) \Rightarrow DIP Switch 1=ON, 2=OFF. The ultimax mode is mentioned here, too. The start address is \$e000 (0xE000). Referring to Table 1, J6 has to be set to $\overline{\text{ROMH}}$. The size is \$2000 (which is hexadecimal for 8k). Hence jumper J5 is set to "switch". It is assumed, that the binary is programmed to the first 8k of the EPROM, so the address lines A15, A14 and A13 are L, L, L \Rightarrow the switches 3-5 are ON.

Item	cartconv	Setting
$\overline{\text{GAME}}$	0 (= LOW)	SW1-1 = ON
$\overline{\text{EXROM}}$	1 (= HIGH)	SW1-2 = OFF
size	\$2000 (=8k cartridge)	A13 (J5) = "Switch"
start	\$E000	$\overline{\text{OE}}$ (J6) = $\overline{\text{ROMH}}$
EPROM offset	\$2000	A15...13 = LLL \Rightarrow SW1-3 = ON SW1-4 = ON SW1-5 = ON

Now the deadtest.bin file can be generated:

```
C:\cartconv>cartconv -i deadtest.CRT -o deadtest.bin
Input file : deadtest.CRT
Output file : deadtest.bin
Conversion from Generic Cartridge .crt to binary format successful.
```

4.3. Example II

```
C:\cartconv>cartconv -f diag04.crt
CRT Version: 1.0
Name: 586220PLUS_0.4
Hardware ID: 0 (Generic Cartridge)
Mode: exrom: 0 game: 1 (8k Game)
offset sig type bank start size chunklen
$000040 CHIP ROM #000 $8000 $2000 $2010
total banks: 1 size: $002000
```

Here, the Hardware ID is 0 (Generic Cartridge) again. The Versa64Cart is suitable for running the software. Now, it is assumed, that the first 8k are already in use and the binary should be programmed to the second 8k slot of the EPROM.

Item	cartconv	Setting
$\overline{\text{GAME}}$	1 (= HIGH)	SW1-1 = OFF
$\overline{\text{EXROM}}$	0 (= LOW)	SW1-2 = ON
size	\$2000 (=8k cartridge)	A13 (J5) = "Switch"
start	\$8000	$\overline{\text{OE}}$ (J6) = $\overline{\text{ROML}}$
EPROM offset	\$2000	A15...13 = LLH \Rightarrow SW1-3 = ON SW1-4 = ON SW1-5 = OFF

The binary conversion is exactly the same like in Example I.

4.4. Example III

```
C:\cartconv>cartconv -f neutron.crt
CRT Version: 1.0
Name: NEUTRON
Hardware ID: 0 (Generic Cartridge)
Mode: exrom: 0 game: 0 (16k Game)
offset sig type bank start size chunklen
$000040 CHIP ROM #000 $8000 $4000 $4010
total banks: 1 size: $004000
```

Again, it is assumed, the binaries should be programmed to the first 16k of the EPROM.

Item	cartconv	Setting
$\overline{\text{GAME}}$	0 (= LOK)	SW1-1 = OFF
$\overline{\text{EXROM}}$	0 (= LOW)	SW1-2 = ON
size	\$4000 (= 16k cartridge)	A13 (J5) = "16k" $\overline{\text{OE}}$ (J6) = "16k"
start	\$8000	Not relevant in 16k mode
EPROM offset	\$0000	A15...13 = LLL \Rightarrow SW1-3 = ON SW1-4 = ON SW1-5 = ON

The binary conversion is exactly the same like in Example I.

4.5. Example IV

```
C:\cartconv>cartconv -f batman.crt
CRT Version: 1.0
Name: batman
Hardware ID: 5 (Ocean)
Mode: exrom: 0 game: 1 (8k Game)
Warning: game in crt image set incorrectly.
offset sig type bank start size chunklen
$000040 CHIP ROM #000 $8000 $2000 $2010
$002050 CHIP ROM #001 $8000 $2000 $2010
[...]
$01e130 CHIP ROM #015 $8000 $2000 $2010
total banks: 16 size: $020000
```

Here, the hardware ID is **not** 0 (generic). The Versa64Cart is **not** suitable for this software. The size is \$20000, which is 128kB, more than what fits into the memory space of the C64. This kind of software requires a cartridge with a certain automatic bank switching circuit, in this case the Ocean cartridge type and a 27C010 (128kx8bit) EPROM is required.

5. EPROMs

Four different types/sizes of EPROMs can be used with the Versa64Cart, not all settings make sense with them. Their pin out is shown in Table 5.

The effect of the settings and the recommended configurations are shown in Table 6.

27C64											
27C128											
27C256											
27C512											
SOCKET											
Vpp	Vpp	Vpp	A15	1	A15	VCC	28	VCC	VCC	VCC	VCC
A12	A12	A12	A12	2	A12	A14	27	A14	A14	/PGM	/PGM
A7	A7	A7	A7	3	A7	A13	26	A13	A13	A13	n.c.
A6	A6	A6	A6	4	A6	A8	25	A8	A8	A8	A8
A5	A5	A5	A5	5	A5	A9	24	A9	A9	A9	A9
A4	A4	A4	A4	6	A4	A11	23	A11	A11	A11	A11
A3	A3	A3	A3	7	A3	/OE	22	/G/Vpp	/G	/G	/G
A2	A2	A2	A2	8	A2	A10	21	A10	A10	A10	A10
A1	A1	A1	A1	9	A1	GND	20	/E	/E	/E	/E
A0	A0	A0	A0	10	A0	D7	19	D7	D7	D7	D7
D0	D0	D0	D0	11	D0	D6	18	D6	D6	D6	D6
D1	D1	D1	D1	12	D1	D5	17	D5	D5	D5	D5
D2	D2	D2	D2	13	D2	D4	16	D4	D4	D4	D4
GND	GND	GND	GND	14	GND	D3	15	D3	D3	D3	D3

Table 5: EPROM pin compatibility

EPROM	Size	A15	A14	A13	16k
27C512	64kx8	yes	yes	yes	yes
27C256	32kx8	HIGH	yes	yes	yes
27C128	16kx8	HIGH	HIGH	yes	yes
27C64	8kx8	HIGH	HIGH	HIGH	no

Table 6: Settings per EPROM type

In case Vpp is located at a dedicated pin (pin 1), A15 has no effect anymore. A HIGH level is recommended (switch is off) . The /PGM Pin should be set HIGH. The n.c. (not connected) pin should be HIGH (with pull-up) or open. For an 8k EPROM, the 16k setting makes no sense.

6. Startup and Trouble shooting

Before you insert the Versa64Cart into the expansion port of the C64, you should make sure, that there are no fatal failures on it. In the worst case, it will produce a short circuit.

- Check the solder joints on the solder side
- Check the orientation of the socket. The notch is at the side, where the capacitor is
- In case you have used the solder bridges to configure the address, check according to the warning in chapter 2.4 or measure the resistance between pin 1 and 2 (that is GND and +5V) of the edge connector (without an EPROM inserted). It must not be less than about 3kΩ.
- After inserting the EPROM, check if the notch is at the same side like the notch of the socket. Check all pins are properly seated in the socket and not bent inwards or outwards.

After all these points are correct, nothing really bad can happen to your C64 anymore. If you get a black screen or a normal startup display with less than 38911 Basic Bytes free, you might have a configuration problem.

- Did you program the EPROM with a proper *.bin and not with the *.crt file? CRT files are not suitable to program an EPROM. Refer to chapter 4.
- Did you set the configuration bits correctly? ON means LOW
- Did you select the required $\overline{\text{OE}}$ (J6)?
- Did you jumper A13 (J5) as required?
- In case it is a 16k cartridge: Are R1, D1 and D2 placed?

7. Revision History

7.1. Rev. 1.1 \Rightarrow Rev. 1.2

- Schematic and layout were redrawn in Eagle (v 9.2)
- All solder bridges (jumpers) are located on the component side now (the footprint of the jumpers includes the solder bridge option)
- A13...A15 can be configured by solder bridges now
- No test points for A13...A15 anymore
- The jumpers are moved to the outer edge for easier access
- J5 for the configuration of A13 is a 3-pin jumper now
- A reset switch is added
- A configuration table is added on the solder side

7.2. Rev. 1.2 \Rightarrow Rev. 1.3

Some issues with cartridge cases were fixed.

- The diodes D1 & D2 and R1 were moved north by 4.93mm
- D1&D2 moved east by 4.6mm, R1 by 2.54mm
- IC1&C1 moved west by 1.59mm

7.3. Rev. 1.3 \Rightarrow Rev. 1.4

- The width of the contact pads of the expansion port was reduced to 1.5mm and the whole area is free of solder stop mask.

7.4. Rev. 1.4 \Rightarrow Rev. 1.5

- The DIP-Switch SW1 can be replaced with a jumper

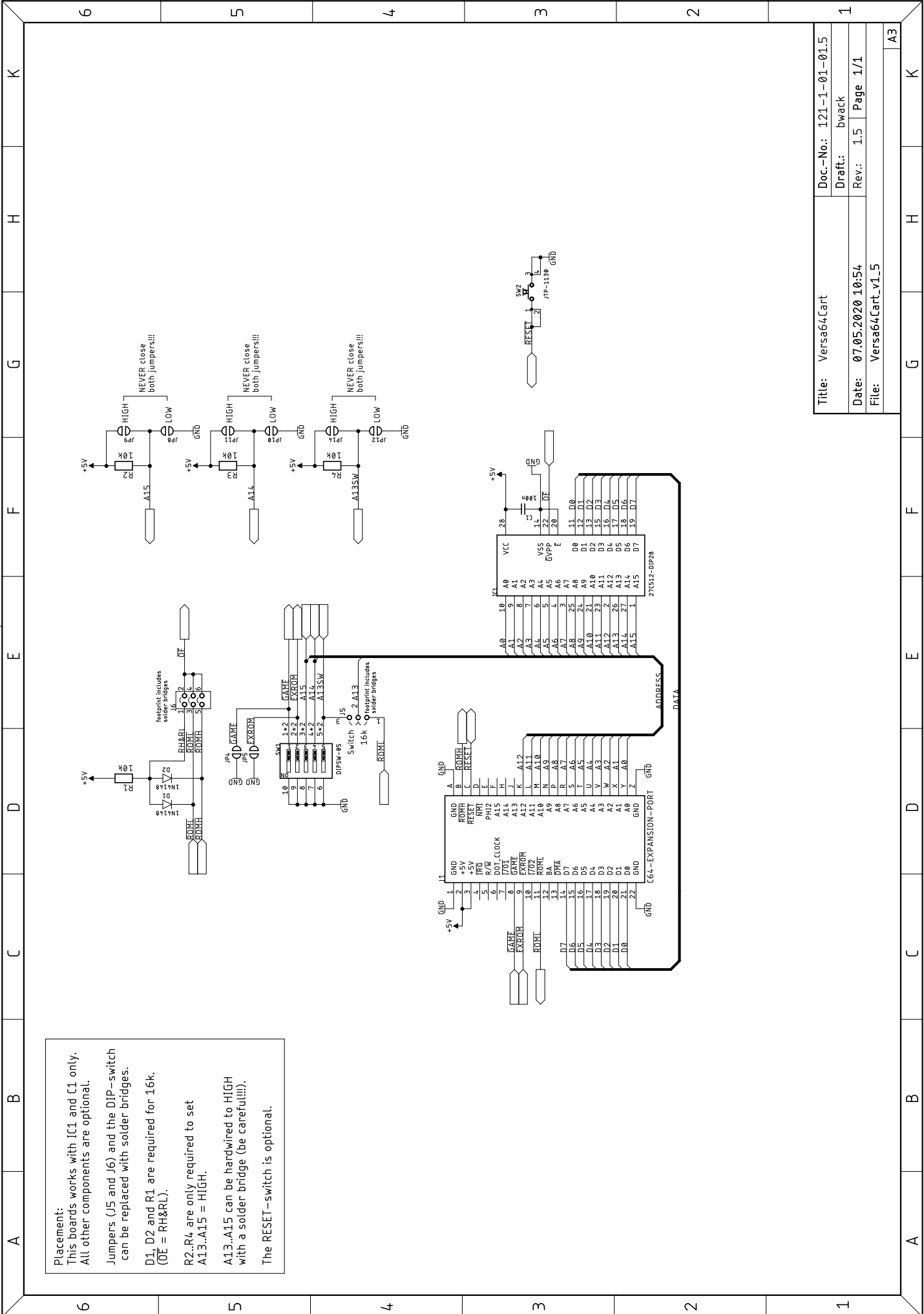

Placement:
 This boards works with IC1 and C1 only.
 All other components are optional.
 Jumpers (J5 and J6) and the DIP-switch
 can be replaced with solder bridges.
 D1, D2 and R1 are required for 16k.
 R2, R4 are only required to set
 A13..A15 = HIGH.
 A13..A15 can be hardwired to HIGH
 with a solder bridge (be careful!!!).
 The RESET-switch is optional.

Title: Versa64Cart	Doc.-No.: 121-1-01-01.5
Date: 07.05.2020 10:54	Draft: bwaack
File: Versa64Cart_v1_5	Rev.: 1.5 Page 1/1
A3	

BWACK	Doc.-No.:121-2-01-01.5	
	Cu: 35µm	Cu-Layers: 2
Versa64Cart_v1_5		
07.05.2020 12:40		Rev.: 1.5
placement component side		

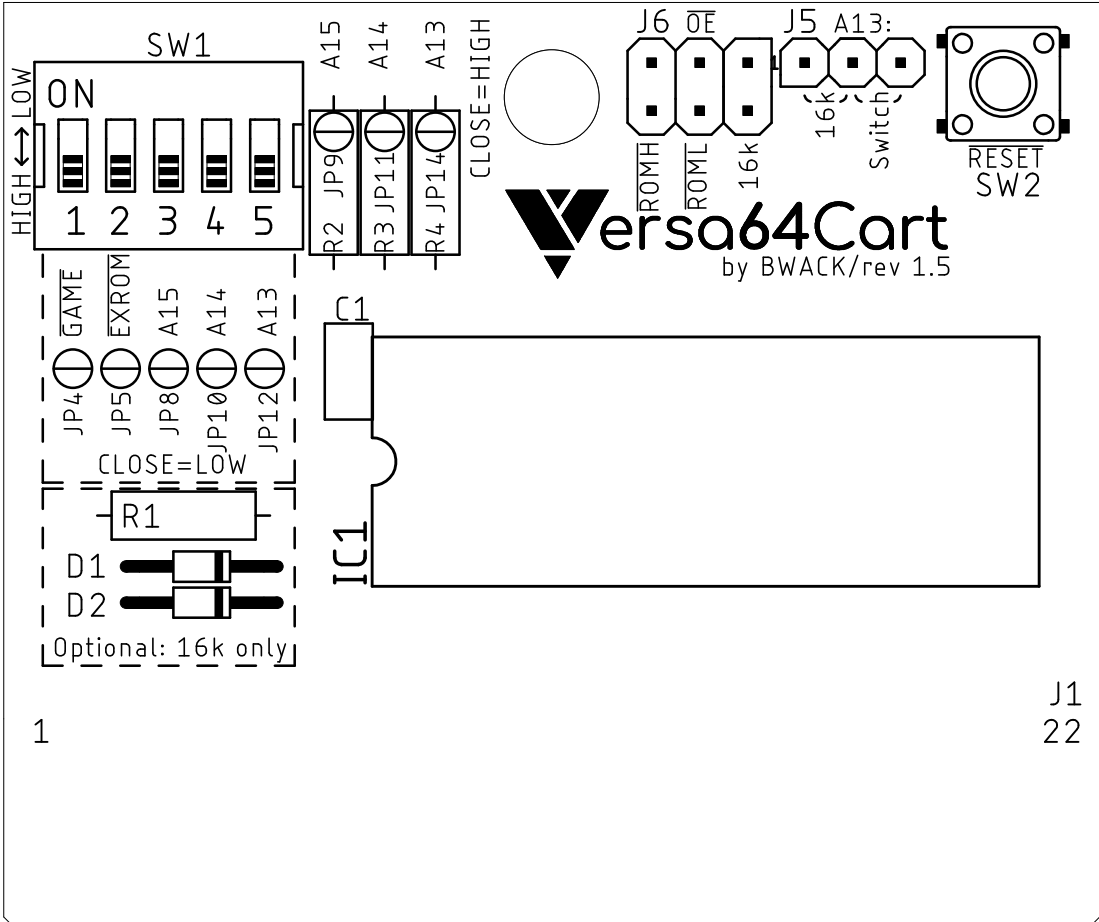

BWACK	Doc.-No.:121-2-01-01.5	
	Cu: 35 μ m	Cu-Layers: 2
Versa64Cart_v1_5		
07.05.2020 12:41		Rev.: 1.5
placement component side		

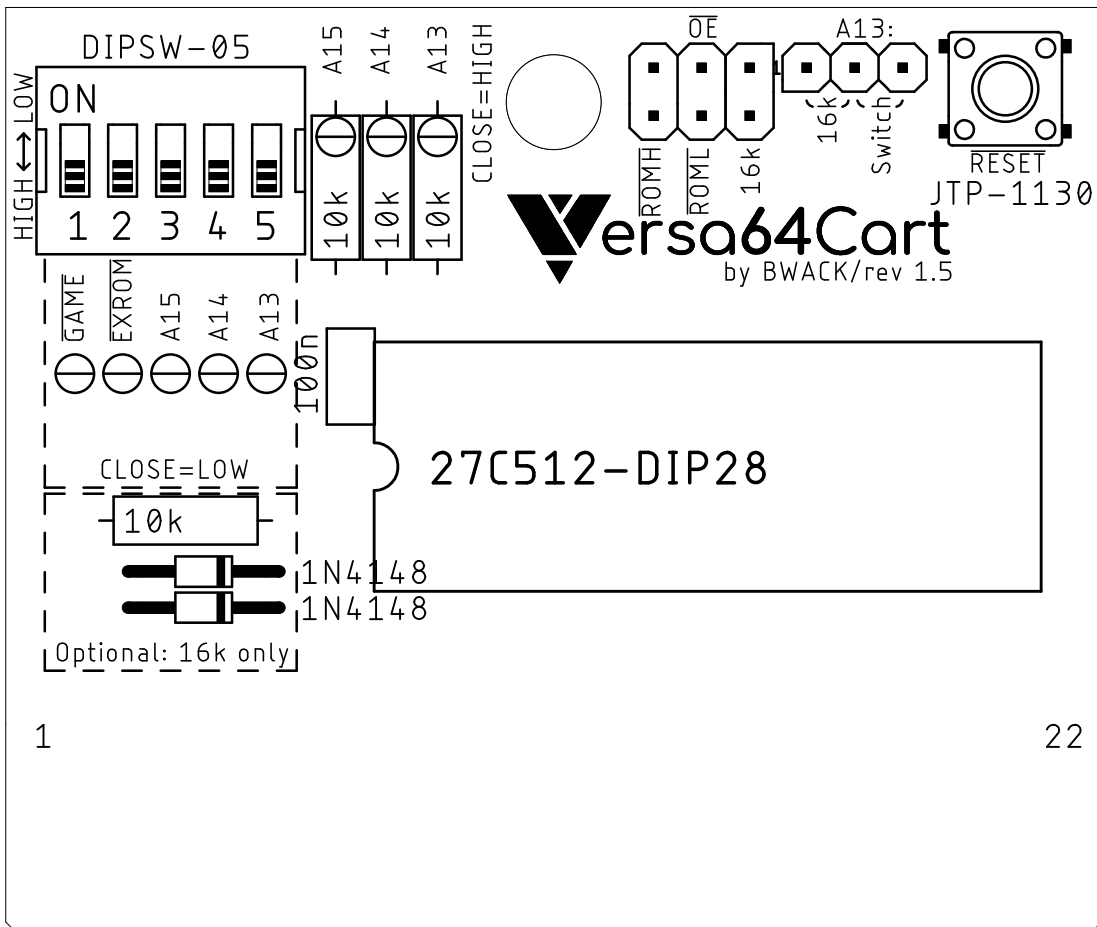

BWACK	Doc.-No.:121-2-01-01.5	
	Cu: 35μm	Cu-Layers: 2
Versa64Cart_v1_5		
07.05.2020 12:41		Rev.: 1.5
placement order side		

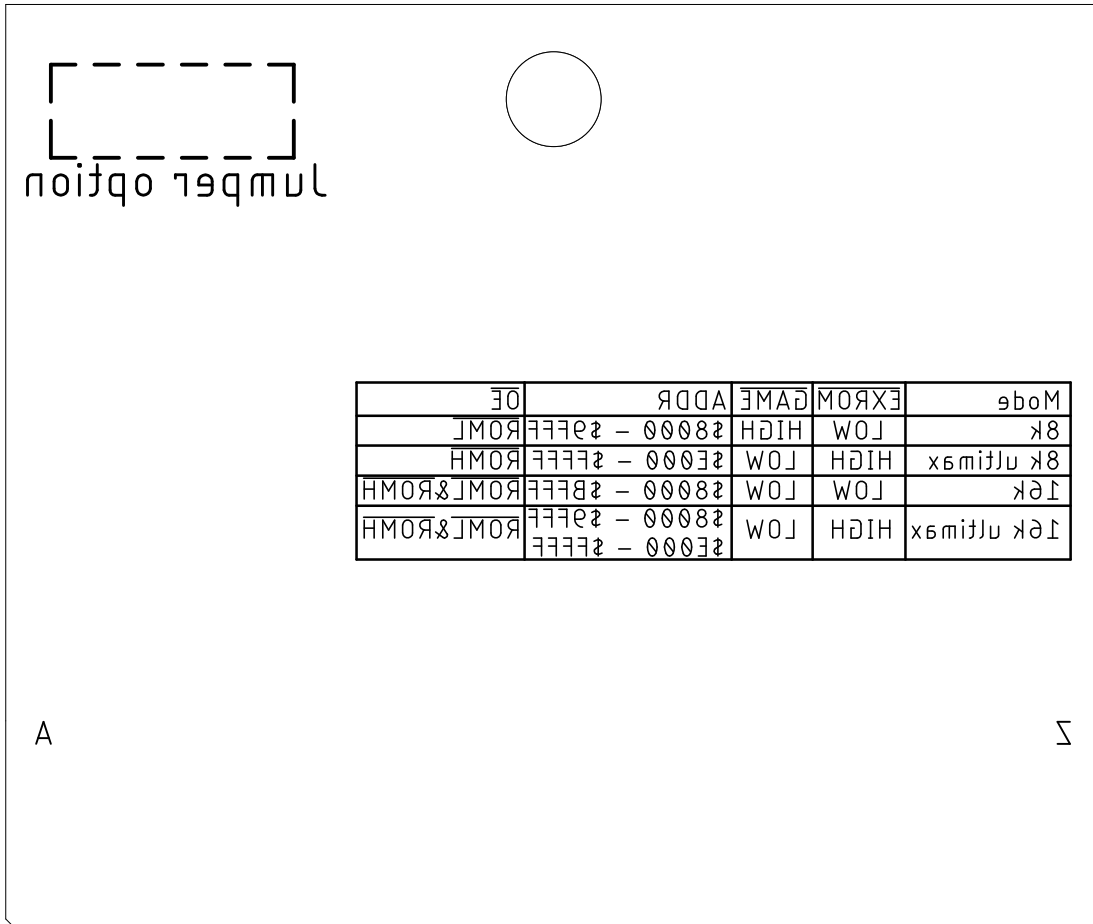

BWACK	Doc.-No.:121-2-01-01.5	
	Cu: 35 μ m	Cu-Layers: 2
Versa64Cart_v1_5		
07.05.2020 12:41		Rev.: 1.5
top		

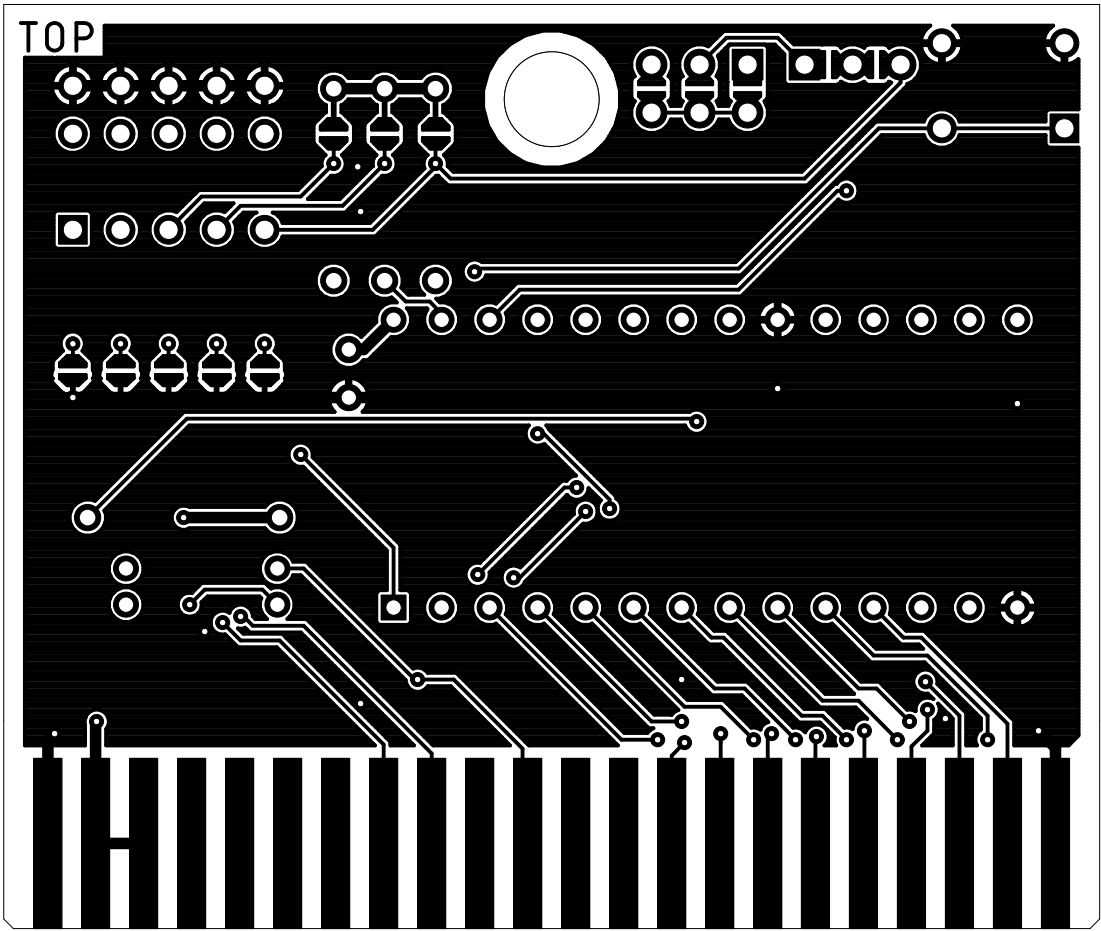

BWACK	Doc.-No.:121-2-01-01.5	
	Cu: 35µm	Cu-Layers: 2
Versa64Cart_v1_5		
07.05.2020 12:41		Rev.: 1.5
bottom		

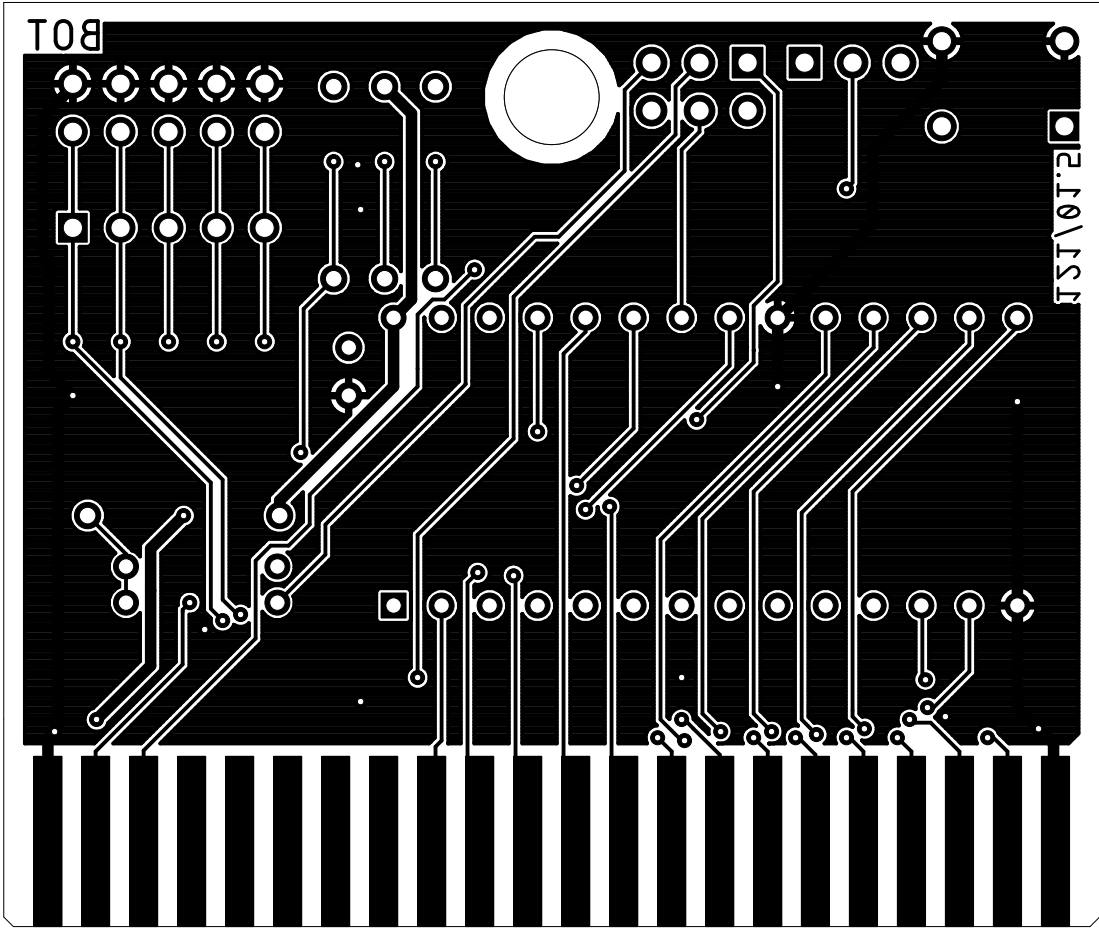

BWACK	Doc.-No.:121-2-01-01.5	
	Cu: 35μm	Cu-Layers: 2
Versa64Cart_v1_5		
07.05.2020 12:41		Rev.: 1.5
stopmask component side		

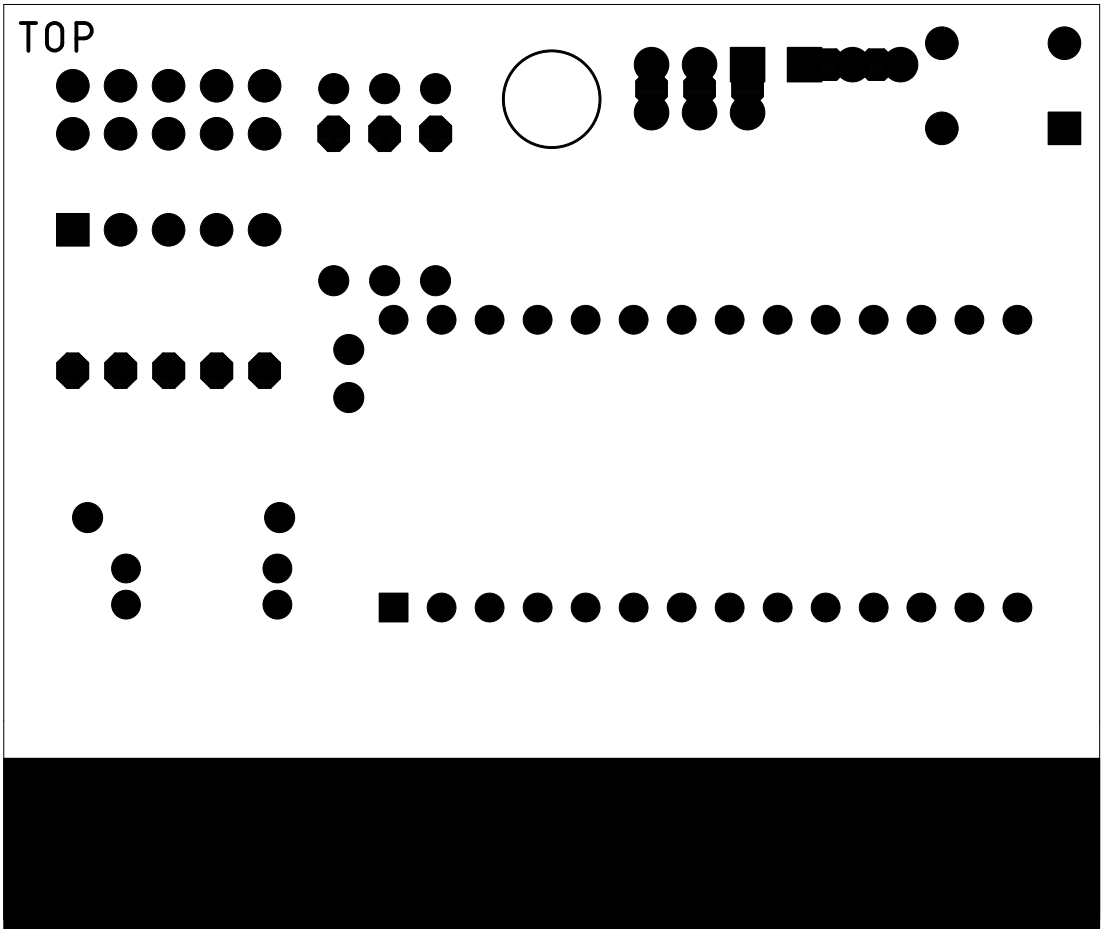

BWACK	Doc.-No.:121-2-01-01.5	
	Cu: 35 μ m	Cu-Layers: 2
Versa64Cart_v1_5		
07.05.2020 12:41		Rev.: 1.5
stopmask solder side		

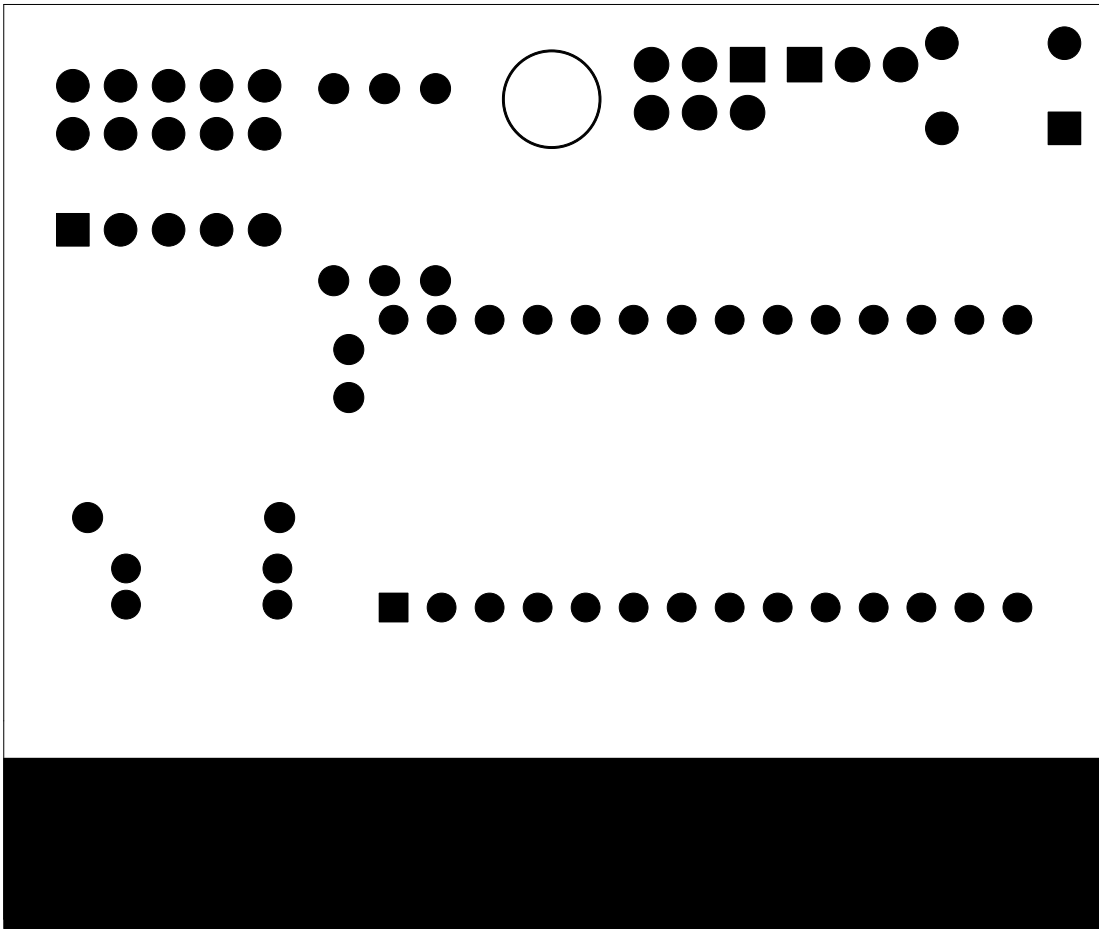

BWACK	Doc.-No.:121-2-01-01.5	
	Cu: 35μm	Cu-Layers: 2
Versa64Cart_v1_5		
07.05.2020 12:40		Rev.: 1.5
placement component side	measures	

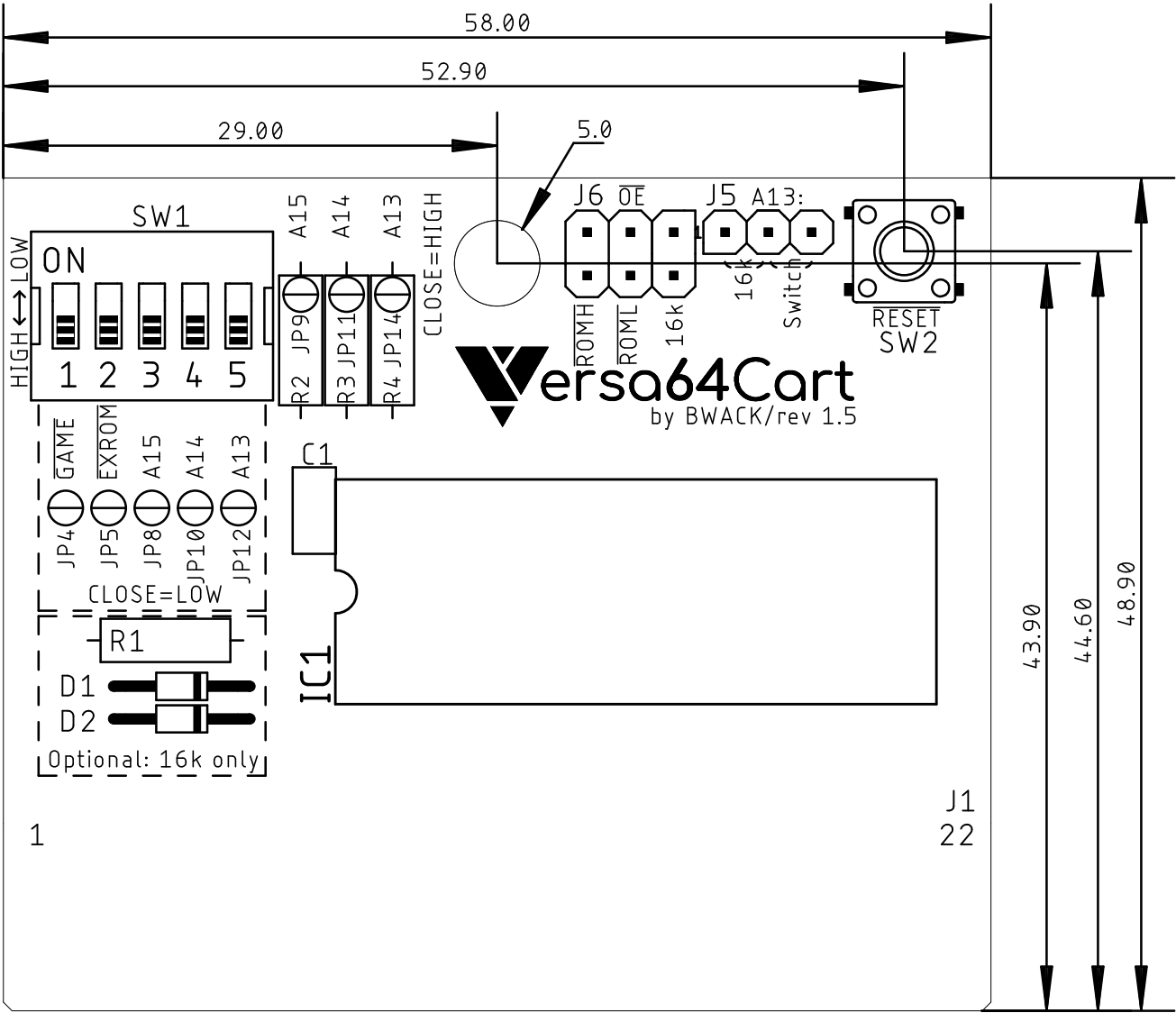

Versa64Cart v1.5

Functional Description

J1 are the contacts, that fit into the Commodore C64 expansion port. The pin numbering is identical to those of the C64. IC1 is the EPROM, which can be socketed or not. C1 is the blocking capacitor, that should help to keep the noise from the supply voltage out of the IC.

The configuration is achieved with the DIP-Switch SW1, jumper J5 and jumper J6. SW1-1 and SW1-2 set the signals $\overline{\text{GAME}}$ and $\overline{\text{EXROM}}$. These signalize the C64 the mode of the cartridge. The switches SW1-3 to SW1-5 are responsible for the (manual) bank select: They configure the three most significant address bits of the EPROM, since those are not asserted by the C64, which only addresses 8kB blocks. The Dip Switch can be replaced with a jumper (2x5).

For 16kB cartridges, a further address bit (A13) is required. Since this kind of cartridge uses both chip selects ($\overline{\text{ROML}}$ and $\overline{\text{ROMH}}$) the signal $\overline{\text{ROML}}$ is used for this purpose. It will be low, while the lower 8kB are addressed and HIGH, while the upper 8kB are addressed.

The 16kB cartridge configuration requires to combine $\overline{\text{ROML}}$ and $\overline{\text{ROMH}}$ to one chip select signal. This function is provided by the wired AND circuit D1, D2 and R1. R1 is pulling the RH&RL signal HIGH. In case one of those signals is low, the RH&RL is driven LOW.

The required chip select signal can be selected with J6.

In 8k mode, the address bit A13 is set by the DIP-switch. Jumper J5 has to be set to the "Switch" position.

While $\overline{\text{GAME}}$ and $\overline{\text{EXROM}}$ utilize the pull-up resistors inside the C64, the address signals A13 to A15 require Pull-Up resistors on the cartridge board (R2-R4). There are solder bridges on the component side of the Versa64Cart, that can be used alternatively to the DIP-Switch to pull each signal low. In case the Pull-Up resistors R2-R4 are not populated, additional solder bridges can be used to set A13 – A15 to a HIGH level (only those, that are set to a HIGH level). It is obvious, that closing the HIGH bridge and the LOW bridge of a signal at the same time produces a short circuit.

SW2 is the reset switch. A pull-up resistor on the C64 mainboard is utilized here.

Versa64Cart v1.5

Testing

Test Description

The test was executed with a Versa64Cart v1.2 (the differences to v1.3, v1.4 and v1.5 are not functional), a C64G (Mainboard ASSY 250469) and an EPROM type ST micro M27C512 10F1. The programming of the EPROM was done with a TL866II Plus programmer.

The following binaries were loaded into the program memory of the programmer, programmed to the EPROM and verified "ok":

Binary	Binary #	Start Address	End Address
Neutron.bin	1	0x0000	0x3FFF
Deadtest.bin	2	0x4000	0x5FFF
586220plus_0_4.bin	3	0x6000	0x7FFF
LalaPrologue.bin	4	0x8000	0xBFFF

The EPROM was inserted into the socket of Versa64Cart, which was then configured, inserted into the C64, the C64 was switched on and the selected binary was run.

Test Execution

Binary #	A15..13	$\overline{\text{GAME}}$	$\overline{\text{EXROM}}$	J6 $\overline{\text{OE}}$	J5 A13	Observation	Testing
1	LLL	L	L	16k	16k	working	ok
2	LHL	L	H	$\overline{\text{ROMH}}$	Switch	working	ok
3	LHH	H	L	$\overline{\text{ROML}}$	Switch	working	ok
4	HLL	L	L	16k	16k	working	ok

Test	Observation	Testing
Does the Cart fit into the slot?	yes	ok
Does the Cart move inside the slot?	The Cart moves 0.9mm from left to right in total. The contacts of the cartridge connector do not leave the contact pad.	ok
Comparison of measures v1.2 vs. v1.1	Both PCBs have the same dimensions. The mounting holes are aligned. The port contacts are aligned, the contacts of v1.2 are wider.	ok
Reset button	Binary #1 can be restarted by pushing the reset button. Some software (e.g. LalaPrologue.bin) does not reset well after pressing the RESET button. It depends on that software, not on the memory bank.	ok
Running cartridge with a breakout board, which adds 90mm to the bus	Binary #1 is running \Rightarrow The bus length is not critical	ok

The critical signal is the $\overline{\text{OE}}$ pulse for the EPROM when the 16k-mode is selected. It can either be too wide or the low level is above 0.7V (the upper margin for a TTL low level).

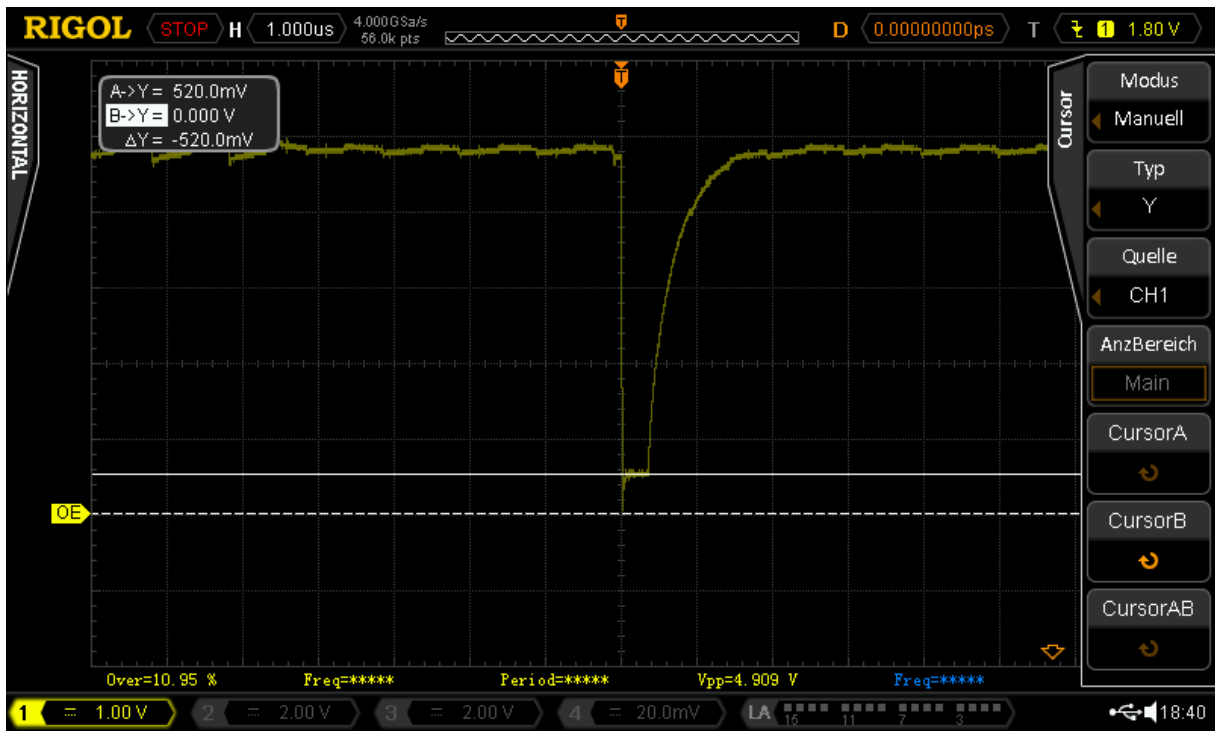

Figure 1: The $\overline{\text{OE}}$ pulse (low level = 520mV)

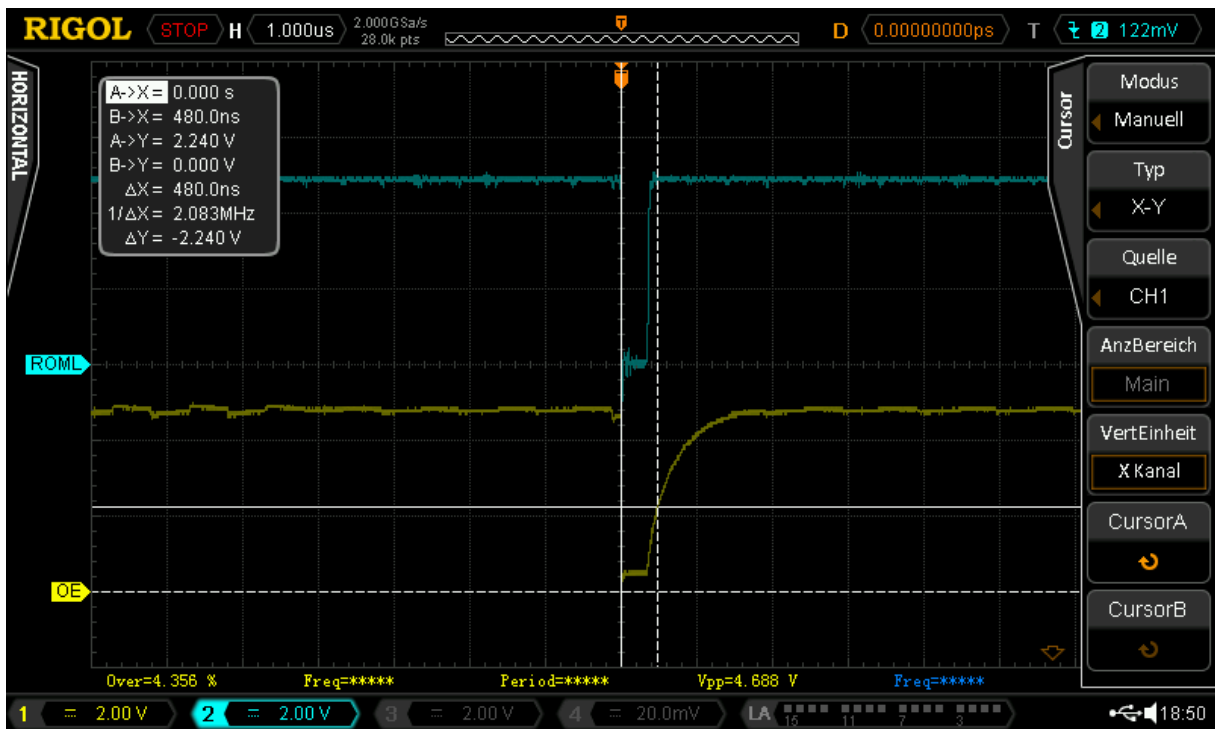

Figure 2: $\overline{\text{OE}}$ pulse (pulse width = 480ns)

Test	Observation	Testing
Low level of the 16k- OE pulse below 0.7V	The low level is 520mV	ok
Pulse width of the 16k-OE pulse less than 500ns (?)	The pulse width is 480ns	ok (?)

Test	Observation	Testing
Neutron.bin & LalaPrologue.bin were programmed into a 27C256, A15 was set HIGH	Both games started and played properly.	ok
LalaPrologue.bin was programmed into a 27C128A, A15 & A14 were set HIGH	Game started and played properly.	ok
1541diagcart.bin was programmed into a 27C164A, A13..A15:HHH, $\overline{\text{GAME}}$: H, $\overline{\text{EXROM}}$: L, $\overline{\text{OE}}$: ROML	Software started and worked properly	ok

Conclusion

- All extra address lines (A15 ... A13) can be asserted
- $\overline{\text{GAME}}$ can be configured properly
- $\overline{\text{EXROM}}$ can be configured properly
- $\overline{\text{ROML}}$ works as a chip select
- $\overline{\text{ROMH}}$ works as a chip select
- The 16k $\overline{\text{OE}}$ works properly, the timing cannot be proved ok, due to a lack of information.
- All binaries are running (16k, 8k Game, 8k Exrom)
- EPROM types tested: ST M27C512, M27C256B, M27C128A, M27C64A

The Versa64Cart is fully functional.

Versa64Cart Rev. 1.5

Bill of Material Rev. 1.50

Pos.	Qty	Value	Footprint	Ref.-No.	Comment
1	1	121-2-01-01.5	2 Layer	PCB Rev. 1.5	2 layer, Cu 35 μ , HASL, 58mm x 48.9mm, 1.6mm FR4
2	1	100n	C-2,5	C1	ceramic capacitor, pitch 2.54
3	4	10k	R-10	R1, R2, R3, R4	resistors
4	2	1N4148	DO-35	D1, D2	diodes
5	1	27C512	DIL28	IC1	EPROM. Also possible: 27C256, 27C128 and 27C64
6	1	socket	DIL28	(IC1)	IC socket for the EPROM
7	1	Pinheader 3x1 pin	1x3p	J5	2.54mm pitch (0.1") pinheader (option: 90°)
8	1	Pinheader 3x2 pin	2x3p	J6	2.54mm pitch (0.1") pinheader (option: 90°)
9	2	Jumper 2.54mm	2.54mm	(J5), (J6)	Jumper to be placed on J5 and J6
10	1	DIPSW-05V	DIPSW-05V	SW1	Standard DIP-Switch with 5 switches (switch side facing up) The DIP-Switch can be replaced with a normal 2x5 jumper.
11	1	JTP-1130	JTP-1130	SW2	Standard 6x6mm tact switch, e.g. Namae JTP-1130 or any other

Rev. 1.2 → 1.3

Pos 1 new board revision

Rev. 1.3 → 1.4

Pos 1 new board revision

Rev. 1.4 → 1.5

Pos 1 new board revision